

## SOIL SAMPLERS FOR QUANTIFYING MICROORGANISMS

Y. BASHAN<sup>1</sup> AND J. WOLOWELSKY<sup>2</sup>

**Two soil samplers—a soil core sampler and a test-tube sampler—and the related techniques for vertical and horizontal quantitative determinations of soil rhizosphere microorganisms are described: both are easily constructed, require no special maintenance, and were successful in field trials. The tools may be adapted to other types of soil research, such as root distribution.**

Soil sampling, particularly for microbiological studies, has several inherent difficulties. First, soil opacity prevents visual selection of a suitable sampling site. In addition, soil is a highly variable entity: a given site may include numerous soil types and subtypes varying in physical, chemical, and biological variables; the level of soil moisture, plant rooting, and agricultural treatments affect soil structure and, in turn, the microflora. These problems and the need to minimize soil mixing and cross-contamination between soil layers complicate the task of obtaining a representative soil sample.

Many soil-sampling methods, including excavations, monolith methods, profile wall and glass wall methods, were developed over the last century (see Böhm 1979 for a recent review). One of the most widely used techniques for obtaining an undisturbed soil sample is by inserting a tube, manually or mechanically, into the soil (Veihmeyer 1929). Based on this principle, various tools were designed, including hand augers and core sampling tubes (Bausch et al. 1977; Borchert 1961; Kelly et al. 1947; Opitz von Boberfeld 1972, 1973; Skirde 1971). However, most of these methods and tools were designed for soil or root sampling and are unsuitable for microbiological studies. Soil-sampling tools for such studies are rare, and those

<sup>1</sup> Corresponding author and recipient of a Sir Charles Clore Fellowship. Dept. of Plant Genetics, The Weizmann Institute of Science, Rehovot 76 100, Israel.

<sup>2</sup> Dept. of Instrument Design, The Weizmann Institute of Science, Rehovot 76 100, Israel.

Received for publication 17 Oct. 1985; revised 22 Jan. 1986.

available are either complicated, laborious to operate, or fit for laboratory use only (Gilmore 1959; Henis et al. 1978).

This paper describes the detailed design and use of two simple tools for easy sampling of soil and rhizosphere microflora at different soil depths and at fixed-in-advance sites in the field.

### MATERIALS AND METHODS

#### *Soils*

Both tools were used in the following soil types and sites: brown-red degrading sand soil (Rehovot, central Israel); loess raw soil (Kibbutz Nir-Am, northwestern Negev); alluvial soil (Kibbutz Negba, northern Negev); loessial sandy soil (Kibbutz Gevulot, western Negev); colluvial-alluvial soil (Kibbutz Mishmar Ha-Emek, western Yizreel Valley); and brown alluvial soil (Vertisols) (Kibbutz Beit Alfa, eastern Yizreel Valley). All soils were practically stoneless; all sites were under wheat cultivation (*Triticum aestivum* and *T. durum*).

#### *Core sampler: construction and use*

Figure 1 is a diagram of the core sampler, which is composed of a polished stainless steel tube (Fig. 1, part 7), a hardened silver steel cutting point (8), and a head (2) adapted with replaceable aluminum caps (1) and Dural handles (4). It also has a compactor rod (9).

The tube is 580 mm long and has 32- and 38-mm inner and outer diameters, respectively, and a 490- × 10-mm open furrow (Fig. 1, 7-1) with depth markers every 50 mm. The cutting point is a modification of the Veihmeyer design (Veihmeyer 1929). It is screwed on to the tube by 38 × 1-mm threads, offset by 2 mm from the tube's end to protect the threads. The cutting point is shaped to form a soil core without shoving the soil ahead of the cutting edge and without compacting the core inside the tube. The inner diameter of the cutting point widens along from 27 mm at the distal end to 32 mm—an essential feature designed to reduce friction on the inner wall of the tube, minimize compression of the core, and prevent the core falling out, once the tube is raised. Core loss, particularly in dry or

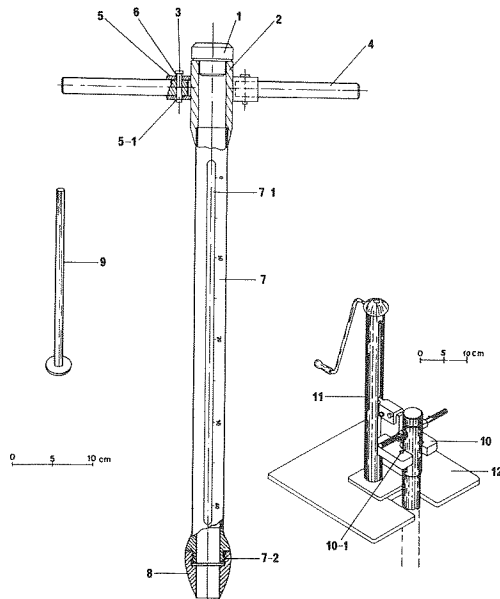

FIG. 1. Vertical core sampler: 1, cap; 2, head; 3, pin; 4, handle; 5, shoulder; 5-1, protuberance; 6, pin hole; 7, tube; 7-1, furrow; 7-2, thread; 8, cutting point; 9, compactor; 10, jaws; 10-1, notch; 11, jack; 12 base.

sandy soils, can also be prevented by lightly tamping the upper end of the core with the compactor (Fig. 1, 9) before lifting the tube.

The head's outer diameter is 50 mm (Fig. 1, 2). Its inner diameter varies throughout. At the top it is 33.4 mm wide to accommodate the sampler's cap, tapering downward to 32 mm along 40 mm. The diameter then increases to 38 mm in two gradations, thus distributing the hammer's force. The head can be either screwed or welded to the tube. For our purposes we adopted the second option.

Two trough-shaped shoulders (Fig. 1, 5) were welded on opposite sides of the head, and two 250 mm long movable handles (Fig. 1, 4) were connected to them by stainless steel pins (Fig. 1, 3 and 6). The handles' shoulder attachment allowed clockwise turning only, to prevent unscrewing the clockwise-screwed cutting point (and lose it when in deep soil). A protuberance (Fig. 1, 5-1.) at the lower surface of each shoulder was designed to fit into a small notch (Fig. 1, 10-1.) in the jaws of the puller (discussed below). Finally, the sampler was equipped with several soft aluminum replaceable caps (Fig. 1, 1) to protect the head from the hammer strokes. The total weight of the sampler is 3.5 kg.

A 6-kg hammer was used; a lighter one was

inefficient; a heavier one (10 to 15 kg) was useful, but rather laborious to operate.

The soil sampler was raised from the hole in the soil by turning the handle clockwise and lifting. However, since this became quite difficult in dry or heavy soils or when several samplings were required, a puller was used. The puller consisted of a car hand jack (2-t lift) (Fig. 1, 11), mounted on a 10-mm-thick steel base (300 × 300 mm). An opening larger than the diameter of the sampler tube, was cut into the base (Fig. 1, 12). The lift-arm of the jack was equipped with U-shaped steel jaws (Fig. 1, 10) 51 mm apart. Each jaw was engraved with a notch to accommodate the protuberance on the sampler shoulders, thereby preventing the separation of the puller from the sampler upon lifting. The weight of the puller is 5.0 kg, and a relatively small effort was needed to withdraw the sampler from any of the six soil types under various moisture conditions. The puller has two disadvantages: (a) after being raised to its upper limit it has to be lowered manually to its lowest position, and (b) being relatively heavy, its carriage all over the field is arduous.

Sampling procedure was as follows (Fig. 2): the sampler was placed on the soil over the roots of a plant whose foliage was removed. The entire tube was then driven into the soil by several hammer strokes on the cap to a position where only the head was above the surface. Then, the cap was removed, and, if necessary, the core was lightly tamped with the compactor. The U-shaped jaws of the puller were placed beneath the sampler shoulders, and the sampler was raised manually, usually within 1 to 2 min. Because large forces develop during lifting, particularly in dry soils, the notches on the jaws must fit the protuberances on the shoulders. Lifting the sampler was relatively easy and was often carried out by our less robust technicians.

After the sampler was withdrawn, the cutting point was unscrewed. Under wet soil conditions this should be carried out by Ridgid chain wrenches (Ridge Tools, United States). To avoid compressing the soil core, it was felt advisable not to push the core out of the tube. Rather, using a flame-sterile, 9-mm-wide stainless steel spatula, the soil core was cut through the furrow, according to the depth markers, and the 50-mm-long segments were removed sequentially through the cutting point to hermetically closed and marked plastic bags.

FIG. 2. Vertical core sampler in use in the field: top, before insertion; bottom left, at withdrawal; right, the cutting point.

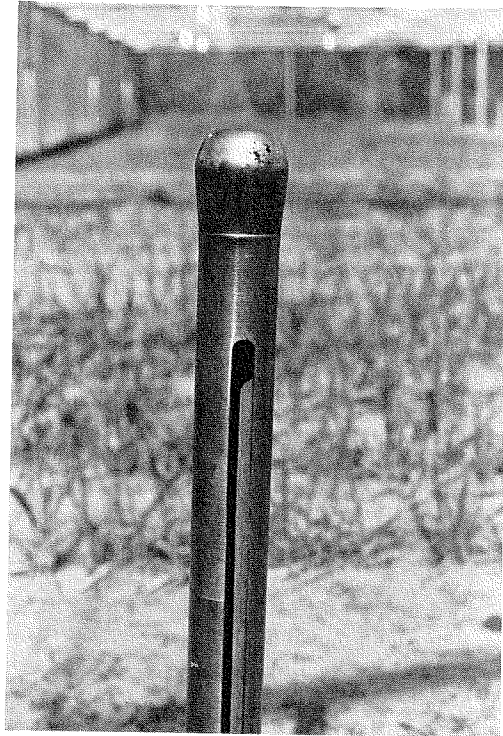
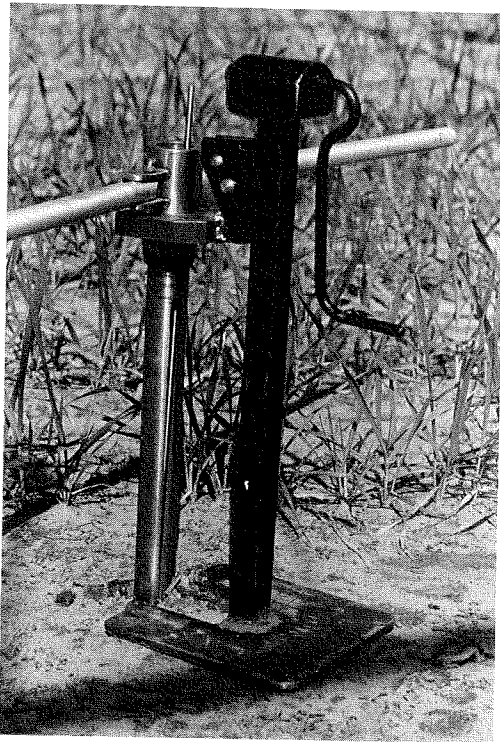
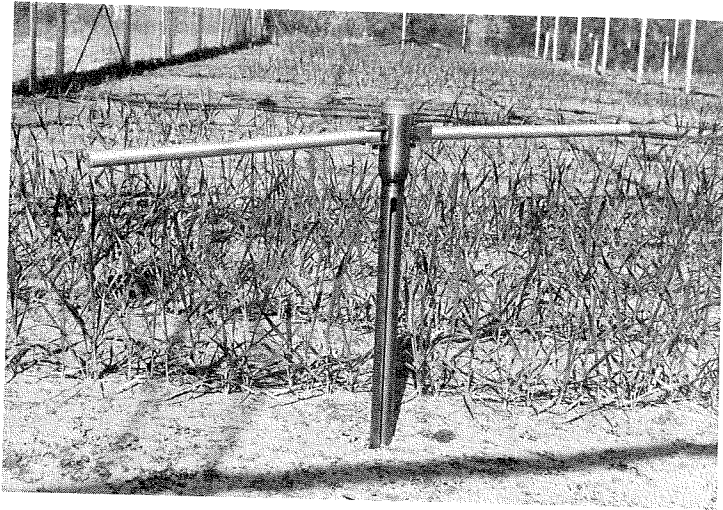

For successful operation, the sampler had to be clean. So, after each core was removed, a long-armed rough brush was used to remove the remaining adhered soil from the tube. Also, soil particles often penetrated the threads of the cutting point during core removal. If the screw threads were not thoroughly cleaned, this could cause a loose fit between the tube and the cutting point when the latter was screwed back on,

resulting in breakage of the cutting point due to forces developed by hammering at the next sampling. After cleaning and rescruwing the cutting point, the sampler was sterilized by alcohol-flaming before the next sampling. The main advantages of the core sampler are: soil samples were withdrawn undisturbed, and no problem of soil compaction was encountered in the six types of soil tested; a relatively small force was needed

to insert or raise the tool from the soil. Sampling time was relatively short (up to 15 min for the whole procedure under field conditions), allowing for extensive samplings. The tool is rustless and light and requires no lubrication, as do previously described tools (Veihmeyer 1929; Gilmore 1959; Böhm 1979). The cutting head is removable by hand, and removal of samples from the tube was quick and simple. The core sampler has several minor disadvantages: in muddy soil or overirrigated soils, it was impossible to take an accurate amount of sample, and cleaning the tool was time consuming. This problem can be easily overcome by proper planning of the sampling schedule. Additionally, the core volume is relatively small, and many samples were needed for a precise determination of soil microflora in a given area. Finally, the outer surface of the core was often contaminated with microorganisms from layers that the cutting point passed through. However, when only rhizosphere bacteria were studied, this undesirable trait was negligible.

*Test-tube soil sampler: construction and use*

This sampler has two parts: a stainless steel folding ruler (Fig. 3, 3) and a hand-push piston (Fig. 3, 1 and 2) made of a 10-mm-thick aluminum base (Fig. 3, 1) and a hard PVC piston (Fig. 3, 2). The cross-shaped base provides for a large contact area with the soil and minimizes the damage to the plants. To fit the test tube, an 18-mm-diameter hole (Fig. 3, 1-2) was drilled in the center of the base and extended on both sides to form a 60-mm-long, 12-mm-wide bay (Fig. 3, 1-3) for viewing the sampling area. Two upright piston shafts (10 mm thick, 110 mm long) (Fig. 3, 1-4) were argon-welded on both sides of the central hole to fit into two 10.2-mm furrows (Fig. 3, 2-1) on the PVC piston. Thus, the piston could move freely along the shafts. Two stainless steel pins (50 mm long, 8 mm in diameter) (Fig. 3, 1-5) were screwed to the upper part of the shafts and two similar pins to the piston at its lowest part (Fig. 3, 2-4) to prevent the disassembly of the piston from the base. The piston was equipped with a rounded flat PVC head (120 mm in diameter) for easy grasping (Fig. 3, 2-5). In addition, a hole 16 mm in diameter and 7 mm long was drilled into the piston base, and soft PVC was glued into its far end to form the proper receptacle for a standard polyethylene tube. The hand-push piston weighs 1.5

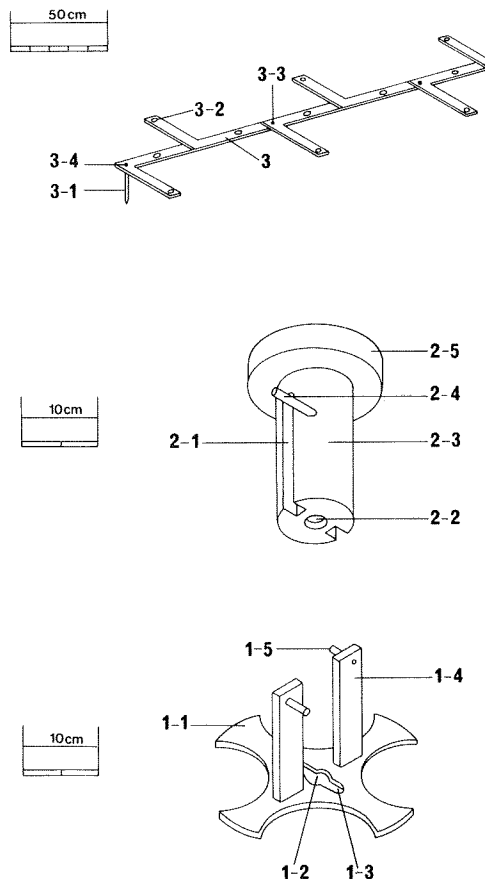

FIG. 3. Laboratory-tube sampler: 1-1, base; 1-2, hole; 1-3, bay; 1-4, upright shafts; 1-5, pin; 2-1, furrow; 2-2, hole; 2-3, hand-push piston; 2-4 pin; 2-5, piston head; 3, folding ruler; 3-1, pin; 3-2, hole; 3-3, rivet; 3-4 hole.

kg. The second part of the tool is a 2-mm-thick stainless steel folding ruler (Fig. 3, 3) covering  $200 \times 50$  cm when open and  $43.5 \times 28$  cm closed. The ruler was constructed from segments fitted together with stainless steel rivets (Fig. 3, 3-3) to provide for  $360^\circ$  movement. When the ruler was unfolded, 11 holes 2 cm in diameter (Fig. 3, 3-2) were drilled, spaced 320 mm apart in a zigzag pattern covering a sampling area of  $1 \text{ m}^2$ . Finally, two stainless steel pins (10 cm long, 5 mm in diameter) (Fig. 3, 3-1) fitted through 6-mm holes at the two edges of the ruler (Fig. 3, 3-4) held the ruler rigidly over the soil surface while sampling. The ruler weighs 2.0 kg.

Sampling operation was as follows (Fig. 4): the ruler was unfolded at the sampling site and fixed to the soil by the two pins. Eleven gamma-

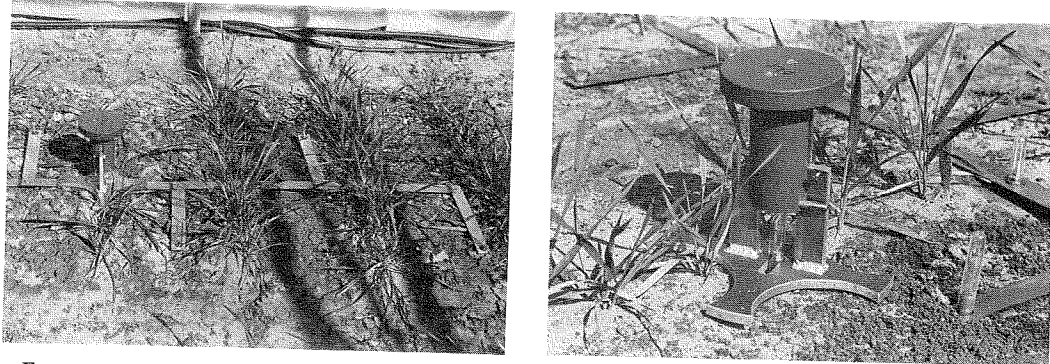

FIG. 4. Laboratory-tube sampler in use in the field: left, fully open; right, close-up of the piston over the tube before insertion into the soil.

irradiated standard polyethylene test tubes (120 mm long, 10 mm in diameter) were marked, opened, and immediately lightly pushed, upside down, into the soil through the sampling holes. The piston was placed over each tube and pressed down to its fullest extent; about 10 mm of the tube remained above the soil surface to ease the withdrawal. After all 11 tubes were driven into the soil, the piston and the ruler were removed. Each tube was hand-pulled from the soil, closed with its original sterile cap, and collected.

The main advantages of the tool are: it is light, small, portable, rustless, and easily arranged on the soil surface, and its operation requires little force. Fewer than 10 min were needed for the full procedure, permitting many samplings per day; the tool gives precise, repeatable constant distribution of tubes over a relatively big area; the tubes are standard, sterile, disposable, and cheap, and no contaminants can disturb the counting number of microorganisms obtained by this method; sampling is possible even in dense foliage, for the damage caused to plants is minimal, and therefore the method can be applied in small experimental plots in the field; the tool requires no maintenance and needs neither cleaning nor lubrication, and the parts do not wear away. The soil sample is completely sterile, and the tool itself need not be sterilized. A minor disadvantage of the tool is that in heavy muddy soil the outer surface of the tubes was covered by mud, which had to be removed before taking the tubes for laboratory analyses.

#### *Determination of rhizosphere microorganisms*

Wheat roots were gently separated from the soil samples and carefully washed with tap water to remove excess soil particles. Roots were homogenized in a high-speed shaft homogenizer (Ystral, West Germany) in 0.06 M potassium phosphate buffer, pH 7.0, in an ice bath. The slurry obtained was further homogenized by a fine glass homogenizer (Kontes, United States), serially diluted in the same buffer, and 0.1-ml aliquots were plated with a glass rod over each of the following media: King-B medium (King et al. 1954) for determination of fluorescent pseudomonads; modified Okon's medium (Bashan and Levanony 1985) for determination of *Azospirillum* spp. and NS medium (Nash and Snyder 1962) for determination of *Fusarium* spp. All plates were then incubated at  $30 \pm 2^\circ\text{C}$ , either for 48 h (for pseudomonads) or for 10 d for the other two groups of microorganisms, and counted.

#### RESULTS AND DISCUSSION

Experience extending over several decades has shown that a soil-sampling tube, compared with various other devices, gives the most accurate and consistent results (Veihmeyer 1929; Böhm 1979). Moreover, under certain conditions, such as gravel in the soil, a tube sampler is the only operable device. The main disadvantage of all soil-sampling tubes, aside from their relatively high cost, is the difficulty of withdrawing them from the ground, especially in dry soils. Additionally, most tools being designed to fulfill

soil or root research requirements, do not allow for easy tool sterilization between successive samplings. Moreover, most of these tools are either too big (Veihmeyer 1929) or too small (Henis et al. 1978) for microflora determination at a soil depth of 50 cm, at which most of the soil and rhizosphere population is present. Alternatively, other scientists have employed tedious or inaccurate methods of soil samplings, including digging deep trenches in the field and sampling from the wall, hand-pushing laboratory glass tubes into the soil, as reviewed by Burges (1958), or using hand augers, which are not only unsuitable for microbial work, but also tiring to use when a large sample is required and almost useless in stony soils (Böhm 1979).

Based on the soil core principle, Gilmore (1959) designed a tool that fulfills microbiological requirements, but we found it unsuitable for

a large-scale sampling program. Its operation requires leaving the cutting point underground during the sampling procedure, thus causing several difficulties. The threads often became contaminated with soil particles, resulting in a loose fit between the tube and the cutting point, which could lead to breakage of the cutting point when the hammer force was applied at the next sampling. In addition, withdrawal of the cutting point from a depth of 0.5 to 1.0 m was complicated: often, particularly in dry soil, the hole was filled with soil, burying the cutting point underneath. We also found that the tool became rusty after several flamings with alcohol. Finally, the rounded shape of the cutting point caused difficulties in inserting and withdrawing the tube, particularly in heavy soils.

Our core sampler was designed to overcome some of these difficulties, as indicated earlier in

TABLE 1

*Fluctuations of rhizosphere population of Fusarium spp., fluorescent pseudomonads, and Azospirillum in wheat roots using vertical and test-tube samplers*

Depth, cm	Number of rhizosphere population (propagules/sample)		
	<i>Fusarium</i> spp.	Fluorescent pseudomonads	<i>Azospirillum</i> spp.
Core sampler			
0 <sup>a</sup> -5	4.1 ± 0.7 · 10 <sup>2c</sup>	5.1 ± 0.6 · 10 <sup>4</sup>	3.8 ± 0.8 · 10 <sup>3</sup>
5 -10	3.1 ± 0.6 · 10 <sup>2</sup>	6.7 ± 0.4 · 10 <sup>5</sup>	7.1 ± 0.6 · 10 <sup>3</sup>
10 -15	4.8 ± 0.3 · 10 <sup>1</sup>	4.4 ± 0.7 · 10 <sup>4</sup>	6.1 ± 0.5 · 10 <sup>4</sup>
15 -20	6.7 ± 0.7 · 10 <sup>1</sup>	8.8 ± 0.1 · 10 <sup>4</sup>	1.9 ± 0.7 · 10 <sup>4</sup>
20 -25	1.8 ± 0.8 · 10 <sup>1</sup>	6.1 ± 0.7 · 10 <sup>4</sup>	8.1 ± 0.3 · 10 <sup>4</sup>
25 -30	0	6.7 ± 0.9 · 10 <sup>6</sup>	7.1 ± 0.8 · 10 <sup>4</sup>
30 -35	0	8.9 ± 0.3 · 10 <sup>3</sup>	8.8 ± 0.6 · 10 <sup>3</sup>
35 -40	0	4.1 ± 0.7 · 10 <sup>3</sup>	7.1 ± 0.3 · 10 <sup>3</sup>
40 -45	0	3.7 ± 0.6 · 10 <sup>2</sup>	6.1 ± 0.4 · 10 <sup>2</sup>
45 -50	0	1.2 ± 0.4 · 10 <sup>2</sup>	2.3 ± 0.8 · 10 <sup>2</sup>
tube number			
Tube sampler			
1 <sup>b</sup>	7.1 ± 0.6 · 10 <sup>2</sup>	4.1 ± 0.6 · 10 <sup>5</sup>	8.4 ± 0.8 · 10 <sup>4</sup>
2	8.2 ± 0.5 · 10 <sup>2</sup>	8.7 ± 0.4 · 10 <sup>5</sup>	7.9 ± 0.6 · 10 <sup>4</sup>
3	1.4 ± 0.3 · 10 <sup>2</sup>	6.3 ± 0.5 · 10 <sup>5</sup>	8.9 ± 0.7 · 10 <sup>4</sup>
4	1.8 ± 0.2 · 10 <sup>2</sup>	9.6 ± 0.6 · 10 <sup>5</sup>	6.8 ± 0.8 · 10 <sup>4</sup>
5	9.6 ± 0.3 · 10 <sup>1</sup>	4.1 ± 0.9 · 10 <sup>4</sup>	7.1 ± 0.5 · 10 <sup>4</sup>
6	4.8 ± 0.7 · 10 <sup>1</sup>	3.8 ± 0.7 · 10 <sup>4</sup>	3.8 ± 0.8 · 10 <sup>3</sup>
7	1.1 ± 0.7 · 10 <sup>1</sup>	6.1 ± 0.4 · 10 <sup>4</sup>	8.4 ± 0.2 · 10 <sup>3</sup>
8	3.7 ± 0.9 · 10 <sup>1</sup>	8.7 ± 0.6 · 10 <sup>4</sup>	3.4 ± 0.3 · 10 <sup>3</sup>
9	2.7 ± 0.4 · 10 <sup>1</sup>	1.8 ± 0.7 · 10 <sup>4</sup>	8.4 ± 0.8 · 10 <sup>2</sup>
10	8.6 ± 0.7 · 10 <sup>1</sup>	6.1 ± 0.3 · 10 <sup>4</sup>	6.8 ± 0.4 · 10 <sup>2</sup>
11	9.8 ± 0.6 · 10 <sup>1</sup>	2.1 ± 0.8 · 10 <sup>4</sup>	

<sup>a</sup> Soil surface.

<sup>b</sup> The first four tubes were used for sampling in a wheat plot and the others in the spaces between plots.

<sup>c</sup> Standard error.

the descriptions of the advantages of the tool. Also, because the sampling area was small and plant damage minimal, the tool can be used in small plots. Finally, the tool was intensively used during 2 yr in the field without noticeable abrasion or change of characteristics.

The test-tube sampler, to the best of our knowledge, has no counterpart among tools for soil surface sampling. The method is based on the principle of inserting sterile tubes into the ground in the sampled area, and analyzing the microflora on growth media to arrive at the microbial distribution map. The tool was designed to overcome the following problems raised by Burges (1958) and Williams and Gray (1973): (a) sterile, disposable plastic tubes are fragile and frequently break, especially in dry soil, resulting in injury to the personnel; (b) sampling sites at each plot are never exactly repeatable, resulting in different sizes of the areas examined. These variations increase the sampling error whenever replicated plots are examined (Waksman 1922).

Over a thousand soil samples collected with these tools by our team were used to determine the various rhizosphere microorganisms in the field during 1983-1984 (Bashan et al. unpublished). Table 1 lists a representative sampling, demonstrating fluctuations in wheat rhizosphere population in southern Israel.

Considering our favorable experience in using these tools over many samplings under various soil conditions, we suggest that these simple, reliable, and cheap tools be adopted by those interested in studying rhizosphere microorganisms under field conditions.

#### ACKNOWLEDGMENTS

This paper was written in memory of the late Mr. Avner Bashan for his constant encouragement and interest during this research. We thank Mr. R. Anati and Mr. S. Shayer of the Instrument Design Department, Mr. Z. Vitkon, Mr. E. Stav, and Mr. Y. Edikmann of the mechanical workshop of the Weizmann Institute of Science for careful design and manufacturing of the tools; Mrs. Hanna Levanony, Miss Orit Ziv, and Miss Orna Zamir for technical assistance during soil samplings in the fields; Prof. M. Feldman, from the Department of Plant Genetics, for helpful discussions; and Mr. Y.

Avivi for very careful criticism and editing of the manuscript.

#### REFERENCES

- Bashan, Y., and H. Levanony. 1985. An improved selection technique and medium for the isolation and enumeration of *Azospirillum brasilense*. *Can. J. Microbiol.* 31:947-952.
- Bausch, W., A. B. Onken, C. W. Wendt, and O. C. Wilke. 1977. A self-propelled high-clearance soil coring machine. *Agron. J.* 69:122-124.
- Böhm, W. 1979. Methods of studying root systems. *In* Ecological studies analysis and synthesis, vol 33. W. D. Billings, F. Golley, O. L. Lange, and J. S. Olson (eds.). Springer-Verlag, Berlin.
- Borchert, H. 1961. Ein methodischer Beitrag zur Entnahme von Bodenproben in ungestörter Lagerung. *Z. Pflanzenernaehr. Dung. Bodenkd.* 93:210-214.
- Burges, A. 1958. Micro-organisms in the soil. Hutchinson, London, pp. 44-71.
- Gilmore, A. E. 1959. A soil sampling tube for soil microbiology. *Soil Sci.* 87:95-99.
- Henis, Y., A. Ghaffer, R. Baker, and S. L. Gillespie. 1978. A new pellet soil-sampler and its use for the study of population dynamics of *Rhizoctonia solani* in soil. *Phytopathology* 68:371-376.
- Kelley, O. J., J. A. Hardman, and D. S. Jennings. 1947. A soil sampling machine for obtaining two- three- and four-inch diameter cores of undisturbed soil to a depth of six feet. *Soil Sci. Soc. Am. Proc.* 12:85-87.
- King, E. O., M. K. Ward, and D. E. Raney. 1954. Two simple media for the demonstration of pyocyanin and fluorescein. *J. Lab. Clin. Med.* 44:301-307.
- Nash, S. M., and W. C. Snyder. 1962. Quantitative estimations by plate counts of propagules of the bean root rot *Fusarium* in field soil. *Phytopathology* 52:567-572.
- Opitz von Boberfeld, W. 1972. Zur Problematik des Stichprobenumfanges bei Wurzelgewichtsfeststellungen von Rasengräsern. *Rasen-Turf-Gazon* 3:51-53.
- Opitz von Boberfeld, W., and P. Boeker. 1973. Der Einfluss verschiedener Düngemittel auf die Anhäufung der Wurzelmasse eines Intensivrasentyps. *Rasen-Turf-Gazon* 4:25-27.
- Skirde, W. 1971. Bewurzelung der Rasendecke mit Beispielen für Abhängigkeit und Beeinflussung. *Rasen-Turf-Gazon* 2:112-115.
- Veihmeyer, F. J. 1929. An improved soil-sampling tube. *Soil Sci.* 27:147-152.
- Waksman, S. A. 1922. Microbiological analysis of soil as an index of soil fertility: I. The mathematical interpretation of numbers of microorganisms in the soil. *Soil Sci.* 14:81-101.
- Williams, S. T., and T. R. G. Gray. 1973. General principles and problems of soil sampling. *In* Sampling microbiological monitoring of environments. R. G. Board and D. W. Lovelock (eds.). Academic Press, New York.